

**FT96-Y76V** **MOTORIZED**  
*Owner'S Manual* *Owner'S Manual* *Owner'S Manual* *Owner'S*  
**TREADMILL**



**Caution** *read and understand this manual before operating unit.*

*Owner'S Manual* *Owner'S Manual* *Owner'S Manual*

# SAFETY HINTS

## IMPORTANT: THIS UNIT IS INTENDED FOR HOUSEHOLD USE ONLY

### SAFETY PRECAUTIONS

Thank you for purchasing our product. Even though we go to great efforts to ensure the quality of each product, occasional errors and/or omissions do occur. In any event should you find this product to be defective or missing a part please contact our Customer Service Department.

Your treadmill was designed and built for optimum safety. However, certain precautions apply whenever you use your treadmill. Be sure to read the manual before assembly and operation.

Also, please note the following safety precautions:

**DANGER:** To reduce the risk of electric shock, always unplug the treadmill from the electrical outlet immediately after using and before cleaning.

1. Read OWNER OPERATING MANUAL and all accompanying literature and follow it carefully before using your treadmill.
2. If dizziness, nausea, chest pains, or any other abnormal symptoms are experienced while using this equipment, STOP the workout at once. CONSULT A PHYSICIAN IMMEDIATELY.
3. Never leave the treadmill unattended when plugged in. Unplug from the outlet when not in use and before removing or replacing parts.
4. Never operate the treadmill if it has a damaged cord or plug, if it is not working properly, if it has been dropped, damaged, or exposed to water.
5. Do not pull the treadmill by the power supply cord or use cord as a handle. Keep cord away from heated surfaces and open flames.
6. Fitness equipment must always be installed and used on a flat surface. Do not use outdoors or near water.
7. Do not insert any objects into any openings.
8. Keep children and pets away from this equipment at all times while exercising.
9. Handicapped individuals should have medical approval and close supervision when using this treadmill.
10. Do not place hands or feet under the treadmill. Always keep hands and legs off of the treadmill when others are using it.
11. Never turn on treadmill while standing on treadbelt. Always return the treadmill to slow speed to provide for safe dismount and low speed restart.
  - a-To disconnect, turn all controls to the off position, then remove plug from outlet.
  - b-Use the treadmill only for it is intended use as described in this manual.
  - c-Warm up 5 to 10 minutes before each workout and cool down 5 to 10 minutes afterward. This allows your heart rate to gradually increase and decrease and will help prevent straining muscles.
  - d-Never hold your breath while exercising. Breathing should remain at a normal rate in conjunction with the level of exercise being performed.
  - e-Start your program slowly and very gradually increase your speed and distance.
  - f-Always wear suitable clothing and footwear while exercising. Do not wear loose fitting clothing that could become entangled with the moving parts of your treadmill.
  - g-Do not walk or jog barefoot, in stocking feet or loose fitting shoes or slippers.
  - h-Care must be taken when lifting or moving the equipment, so as not to injure your back. Always use proper lifting techniques.
12. If the supply cord is damaged, it must be replaced by the manufacturer, its service agent or similarly qualified persons in order to avoid a hazard.
13. The appliance is not to be used by children or persons with reduced physical, sensory or mental capabilities, or lack of experience and knowledge, unless they have been given supervision or instruction
14. Children being supervised not to play with the appliance

**WARNING:** Before beginning any exercise program consult your physician. This is especially important for individuals over the age of 35 or persons with pre-existing health problems. Read all instructions before using any fitness equipment. We assume no responsibility from personal injury or property damage sustained by or through the use of this product.

**CAUTION!! Please be careful when opening this unit.**

## **INTRODUCTION**

The treadmill has been designed and constructed to provide trouble free usage and enjoyable exercise. You can greatly improve your understanding and benefits of exercising by carefully reading the instructions given in this manual. Please familiarize yourself with the maintenance advice provided for you.

## **SPECIFICATIONS**

- Drive Motor: 1.75 hp
- Speed Range: 1.0 –18 kmph
- Running Surface: 510 m/m x 1475 m/m
- Incline Level: 0-12 Levels
- Folding Design: Yes



Ø **MAX.USER WEIGHT 130 KGS**

# ASSEMBLY PACK CHECK LIST

## ASSEMBLY PACK CHECK LIST

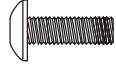

#96. M5 x 10 m/m  
Phillips Head Screw (6pcs)

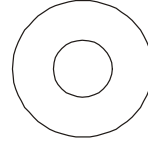

#95. 5/16"x19x1.5T  
Curved Washer (8pcs)

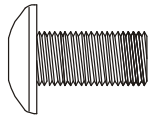

#94. 5/16" x15m/m  
Button Head Socket Screw (14pcs)

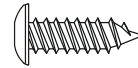

#90. 3.5x12 m/m  
Self Tapping Screw (4pcs)

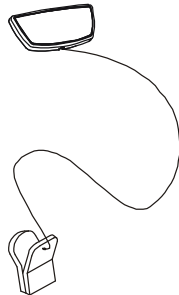

#102. Safety Key (1pc)

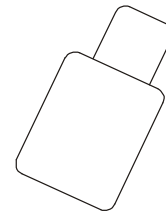

#93. Lubricant (1pc)

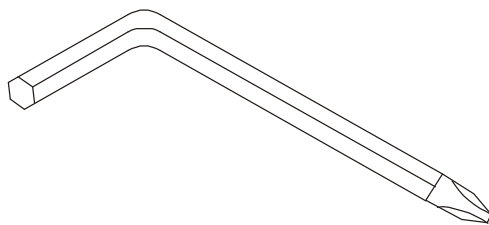

#97. Combination M5 Allen Wrench  
& Phillips Head Screw Driver (1pc)

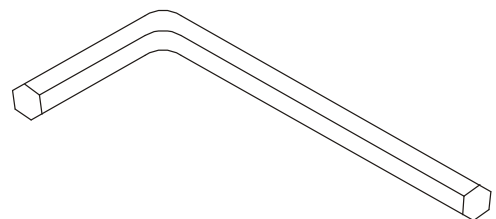

#98. M6 Allen Wrench (1pc)

## ASSEMBLY

### Step 1.

Take out the treadmill from the carton and lay it aside on a smooth level surface.

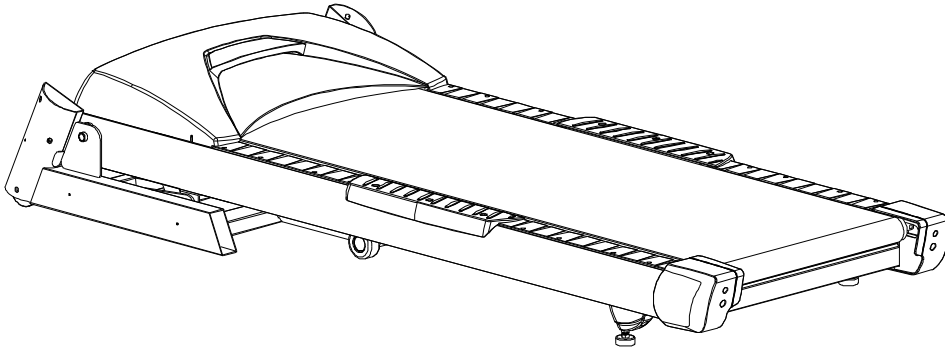

### Step2.

Connect the Lower Computer Cable (38) with the Middle Computer Cable (37).

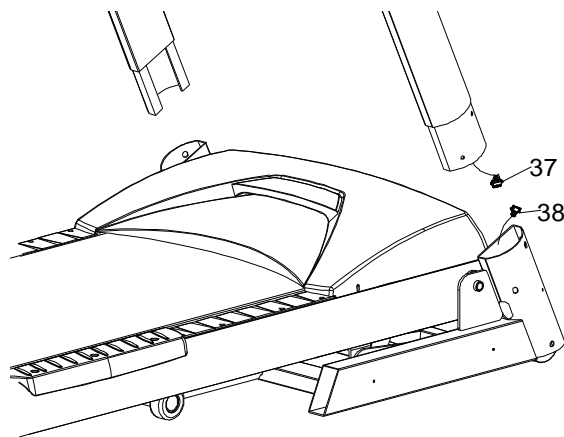

## Step 3

Insert the Handrails (4,5) into the Frame Base with the 8pcs of 5/16"x15m/m Button Head Socket Screws (94) and 4 pcs of 5/16" x 19 x 1.5T Curved Washers (95) - on the bolts for the side of the tubes - using the Combination M5 Allen Wrench & Phillips Head Screw Driver (97). Be careful not to pinch the computer cable while installing the Right Handrail.

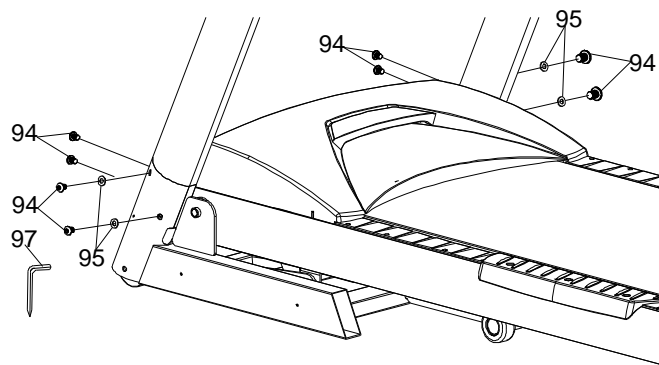

## Step 4.

Install the Left Handrail Cover (41) onto the Left Handrail (4), Right Handrail Cover (40) onto the Right Handrail (5). Make sure they are facing the correct direction and allow them to slide down and sit at the bottom of the tubes.

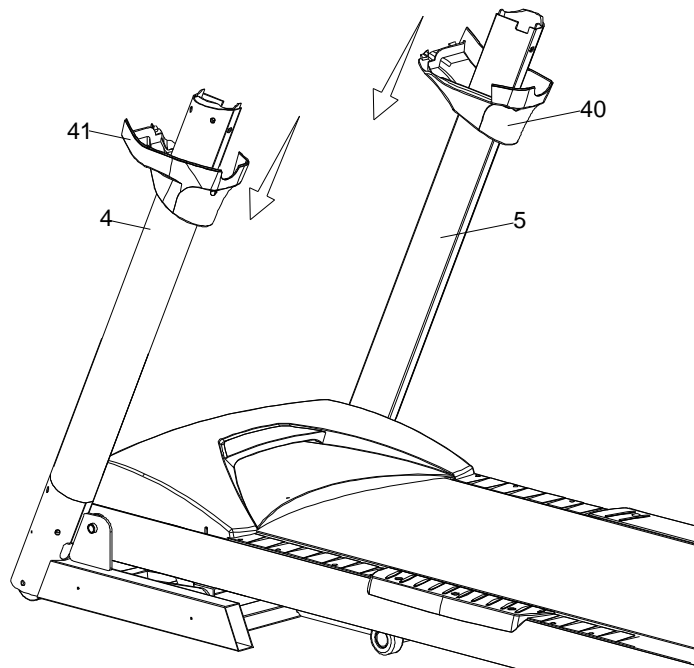

## Step 5.

Connect the Middle Computer Cable (37) with the Upper Computer Cable (36).

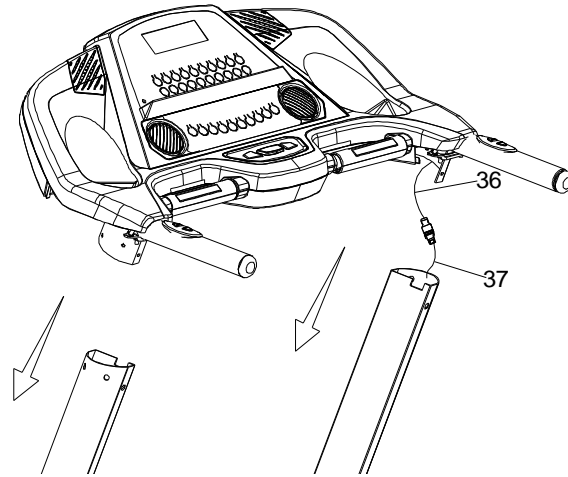

## Step 6.

Install the Console Assembly (39) into the Left & Right Handrails (4,5) with the 6pcs of 5/16"x15m/m Button Head Socket Screws (94) and 4 pcs of 5/16" x 19 x 1.5T Curved Washers (95) using the Combination M5 Allen Wrench & Phillips Head Screw Driver (97). The two bolts in the front do not require washers

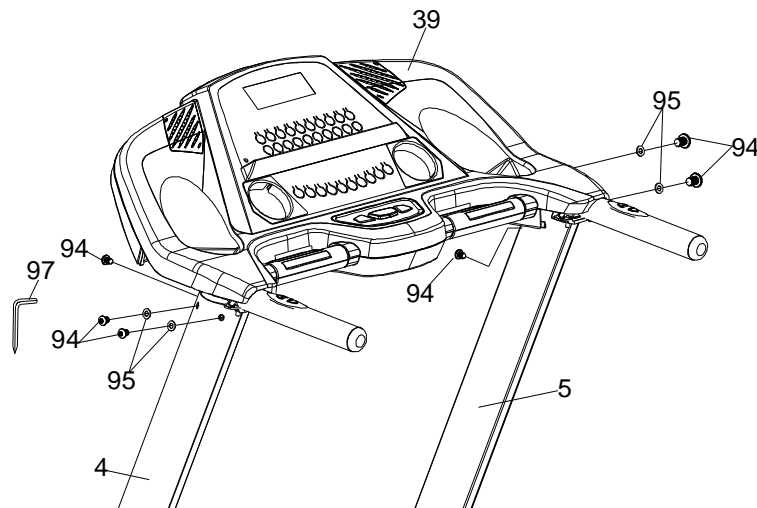

## Step 7.

Install the Left and Right Handrail Covers (41, 40) onto the Console Assembly (39) with the 4 pcs of 3.5x12m/m Self Tapping Screws (90).

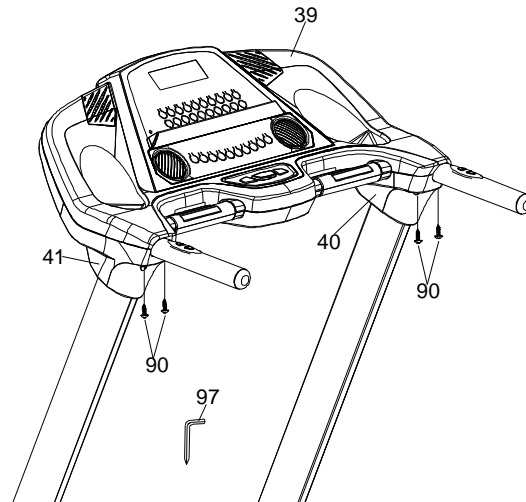

## Step 8.

Install the Frame Base Caps (44,43) onto the Frame Base with 6pcs of M5x10m/m Phillips Head Screws (96).

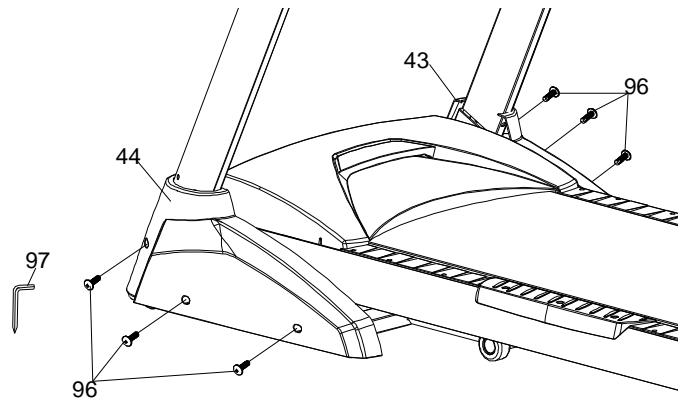

## NOTE:

Please Tighten All Screws After All Components Assembly Complete.

