

PG100

ASSEMBLY AND OPERATING INSTRUCTIONS

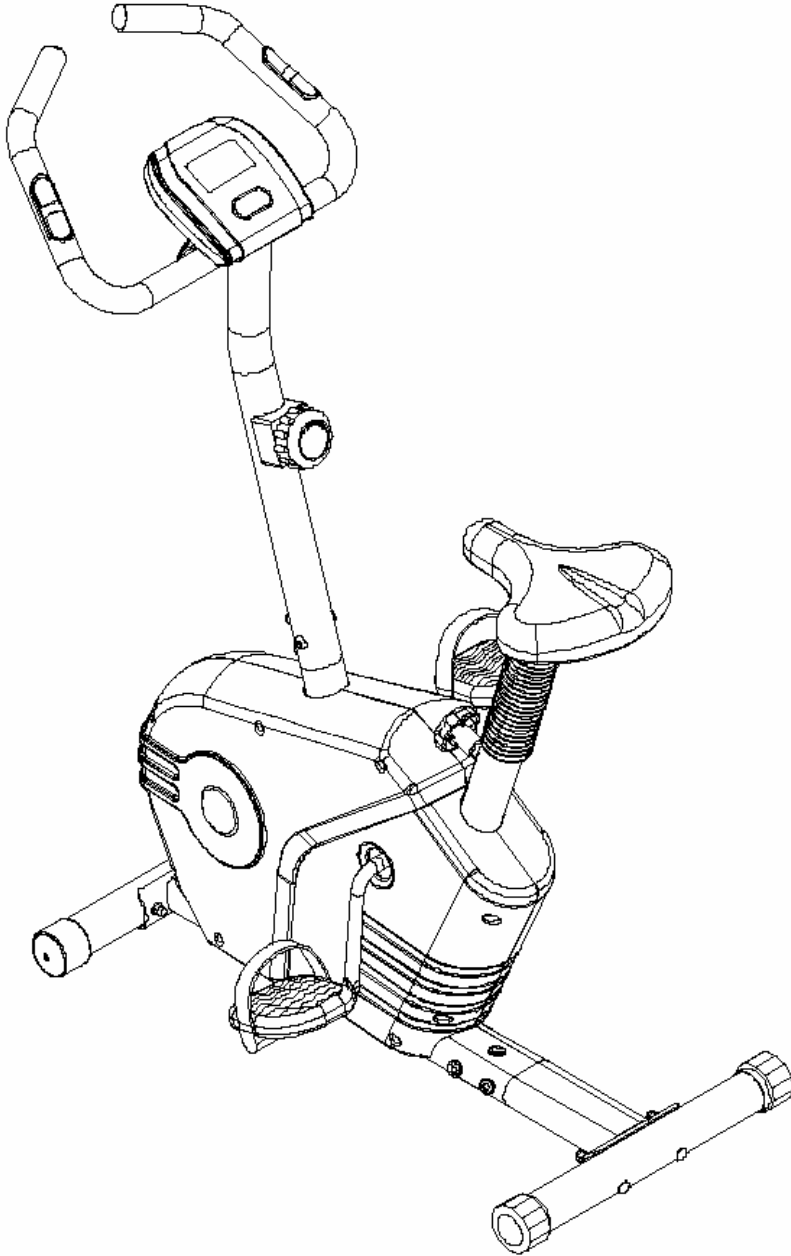

CONCEPT CYCLE

infiniti
FITNESS SYSTEMS

EXPLODE DRAWING

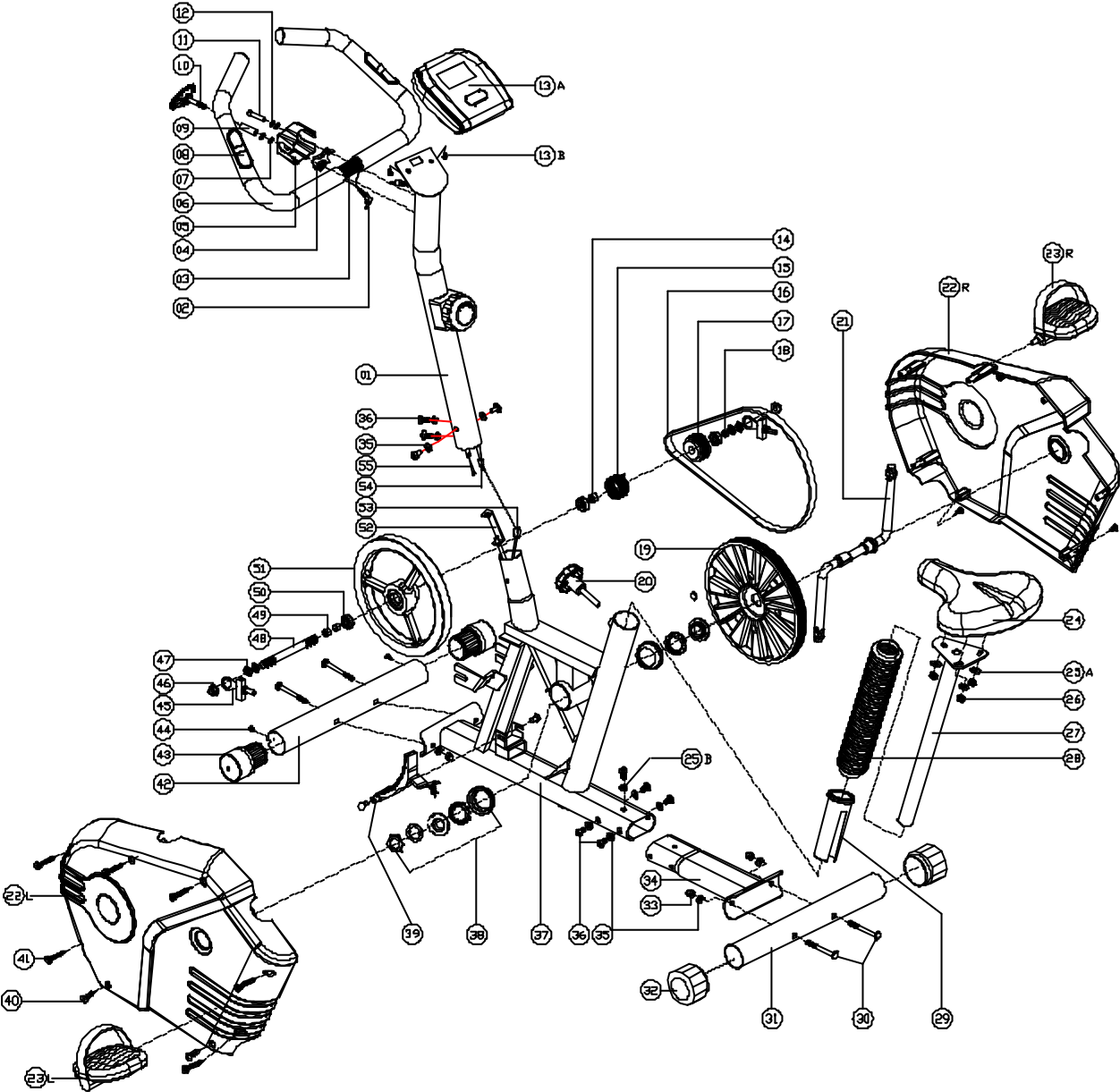

PARTS LIST AND TOOLS

NO	Description	Q' ty	NO	Description	Q' ty
1	HANDLEBAR POST	1	40	SCREW FOR CHAIN COVER	4
2	PULSE CABLE	1	41	SCREW FOR CHAIN COVER	7
3	HANDLEBAR	1	42	FRONT STABILIZER	1
4	METAL COVER FOR HANDLEBAR	1	43	TRANSPORTATION WHEEL	2
5	PLASTIC COVER FOR HANDLEBAR	1	44	SCREW FOR FRONT STABILIZER	2
6	FOAM GRIP	2	45	STAR-KNOB FOR FLYWHEEL	2
7	FLAT WASHER	2	46	NUT FOR FLYWHEEL	2
8	PULSE	2	47	SCREW FOR FLYWHEEL	4
9	METAL BUSH	1	48	AXLE	1
10	T-SHAPE KNOB	1	49	MATEL BUSH FOR FLYWHEEL	2
11	SCREW FOR HANDLEBAR	1	50	BEARING	1
12	SPRING WASHER	2	51	FLYWHEEL	1
13	COMPUTER	1	52	TENSION CABLE (BOTTOW)	1
14	COPPER BUSH	1	53	SENSOR CABLE (BOTTOW)	1
15	SPRING FOR FLYWHEEL	1	54	SENSOR CABLE(UP)	1
16	BELT	1	55	TENSION CABLE (UP)	1
17	SMALL PULLEY FOR BELT	1			
18	METAL BUSH	1			
19	BIG PULLEY FOR BELT	1			
20	KNOB FOR SEAT POST	1			
21	CRANK ARM	1			
22	CHAIN COVER	1			
23	PEDAL	1			
24	SEAT	1			
25	FLAT WASHER	4			
26	SCREW FOR SEAT	3			
27	SEAT POST	1			
28	BELLOW	1			
29	PLASTIC SLEEVE FOR SADDLE POST	1			
30	CARRIAGE BOLT	4			
31	REAR STABILIZER	1			
32	FOOT CAP	2			
33	NUT FOR CARRIAGE BOLTS	4			
34	BASE TUBE	1			
35	WAVE WASHER	12			
36	SCREW FOR BASE TUBE	9			
37	MAIN FRAME	1			
38	B.B. SET	1			
39	MAGNETIC BRAKE SYSTEM	1			

ASSEMBLY INSTRUCTION

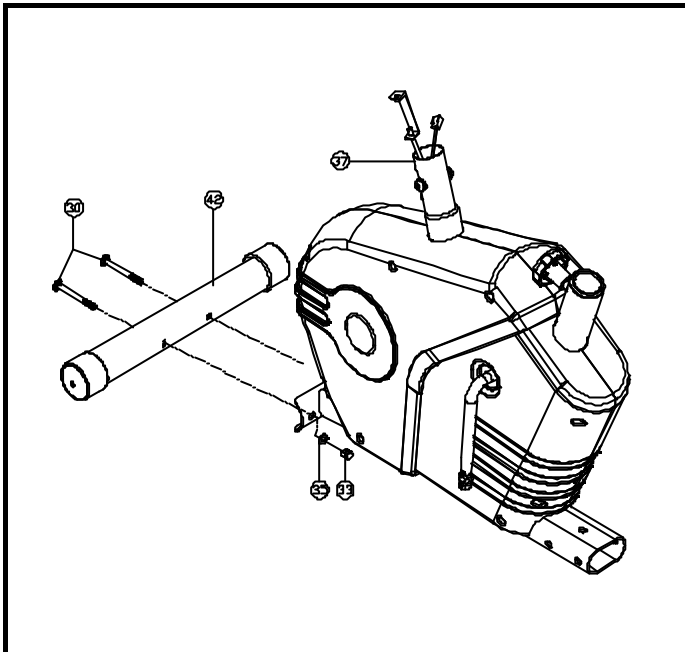

STEP 1

1. Prepare a clean area. Take the main frame bike with all parts out of the carton and put them on such area. Check the parts with the parts list to make sure there's no missing part in the carton.
2. Install the front stabilizer(42) with 2 carriage bolts(30), washers(35) and nuts(33) by using the hand tools. Make sure the transportation wheels are in correct direction.

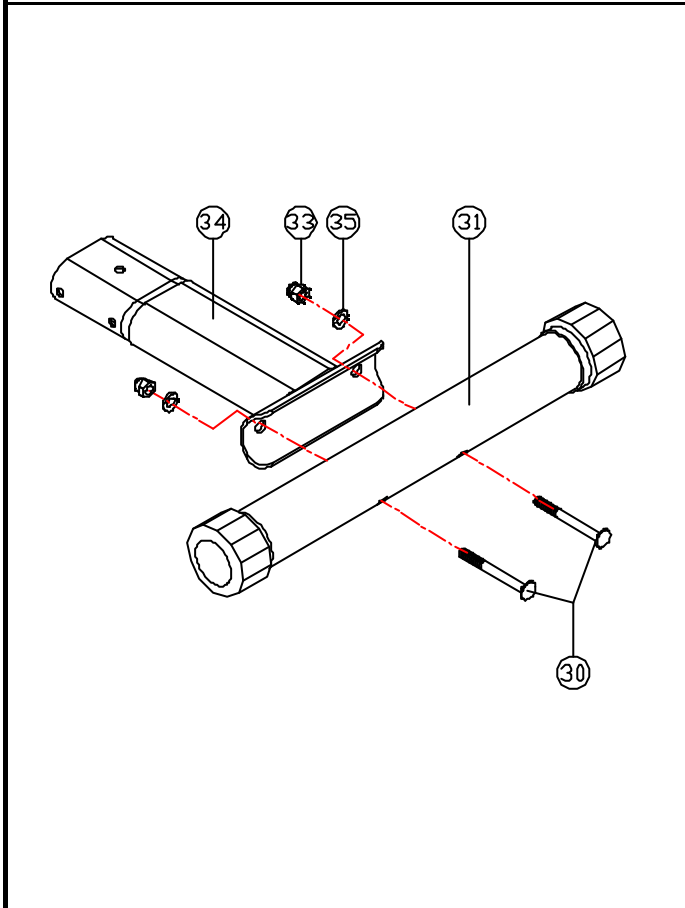

STEP 2

1. Assemble the Rear Stabilizer(31) with 2 carriage bolts(30), washers(35) and nuts(33) by using the hand tools. Adjust the end caps on the rear stabilizer to set up a stable, balanced position.

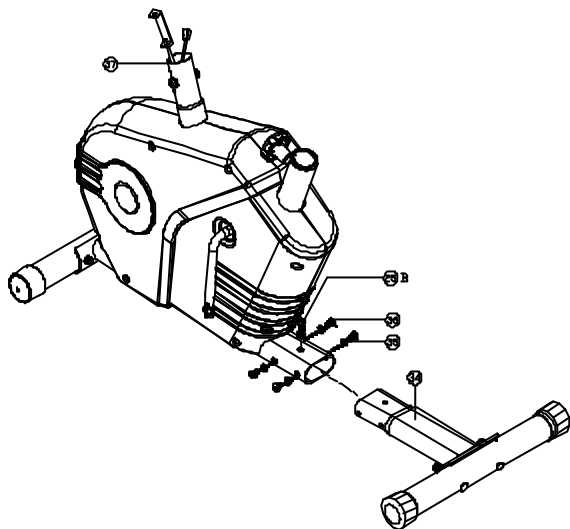

STEP 3

1. Assemble the base tube(34) to the main frame with 5 screws (36) and 1 flat washer (25B) and 4 wave washers(35).

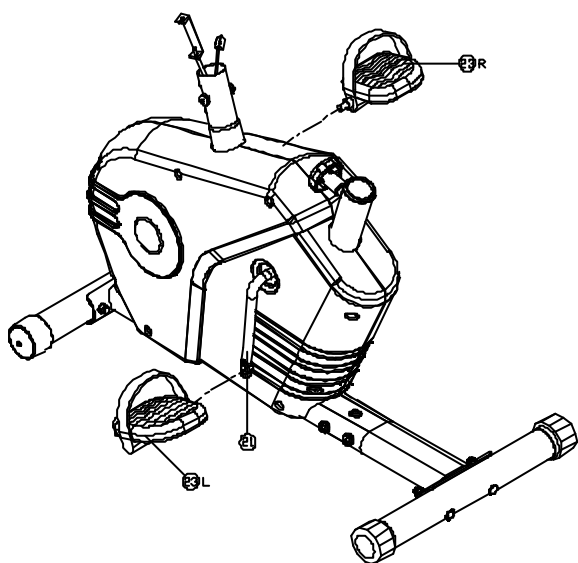

STEP 4

1. Assemble the straps onto the pedals as the sketches. Adjust the ideal length of the straps according to your size of feet.
2. Install the left pedal(23L) to the left crank arm and screw the right pedal(23R) onto the right crank arm (Set the pedal bolts counter-clock wise).

(Note: when assembling the straps to the pedals, make sure the right strap to the right pedal, there's an "R" on both strap and pedal and left strap to the left pedal, there's an "L" on both strap and pedal.)

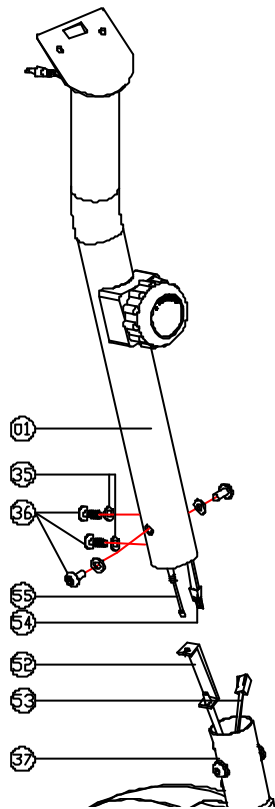

STEP 5

1. Release 4 Allen bolts (36) and wave washers(35) which are pre-assembled on the main frame (37).
2. Install the handlebar post(01) onto the main frame(37). Turn the Tension Control Knob back and forward to make sure it is smoothly moving. If not, re-assemble the tension control cables(52,55). Follow the instruction below to assemble the tension cable.
3. Assemble the cables (53,54) of the exercise computer between the main frame and the handlebar post.
4. Use bolt driver to fasten the Allen bolts(36) and wave washers(35).

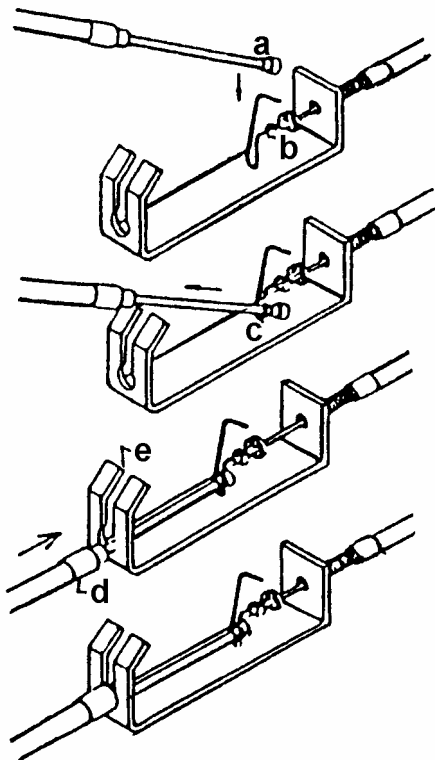

1. Draw the tension cable out of the handlebar post. Make sure tension knob is at 1 (minimum position).
2. Connect the tension cable head (a) with the other cable head (b) by pushing it into notch (c). Draw the tension cable with the copper end (d) to insert it to the metal bracket notch (e).
3. Fix the handlebar post(01) carefully to the main frame(37) to avoid cutting off the computer cable. Fasten the handlebar post to the main frame with 4 Allen bolts(36) and wave washers(35).

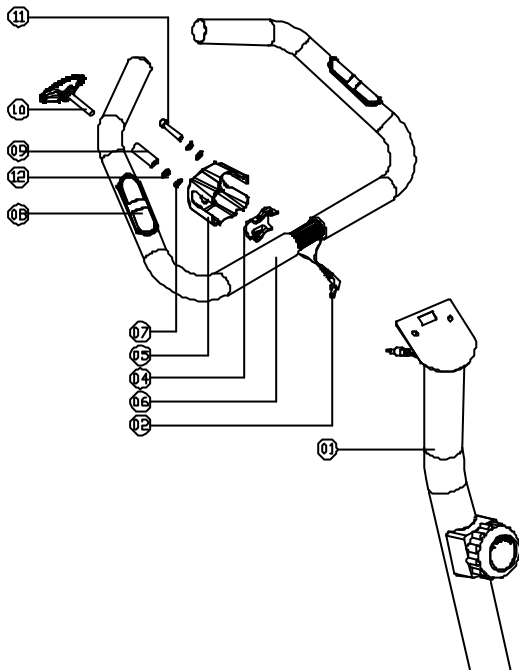

STEP 6

1. Install the handlebar (02) onto the bracket of the handlebar post(01). Make sure the pulse cable is outside the top of the handlebar post with the computer bracket (plate) protruded on top
2. Put the metal cover(04) pressing the handlebar. Then fix handlebar with one flat washer (07), one spring washer(12), and an Allen bolt (11) to fasten them firstly and then assemble the plastic cover to the handlebar by washers(7&12) and bushing(09) and T-knob(10).
3. Adjust the handlebar to be a suitable angle. Fasten the Allen bolt(11) and T-knob(10) securely.

Precaution:

Before using this bike, be sure that you have fastened the Allen bolt(11) and T-knob(10) on the handlebar. This is a very important

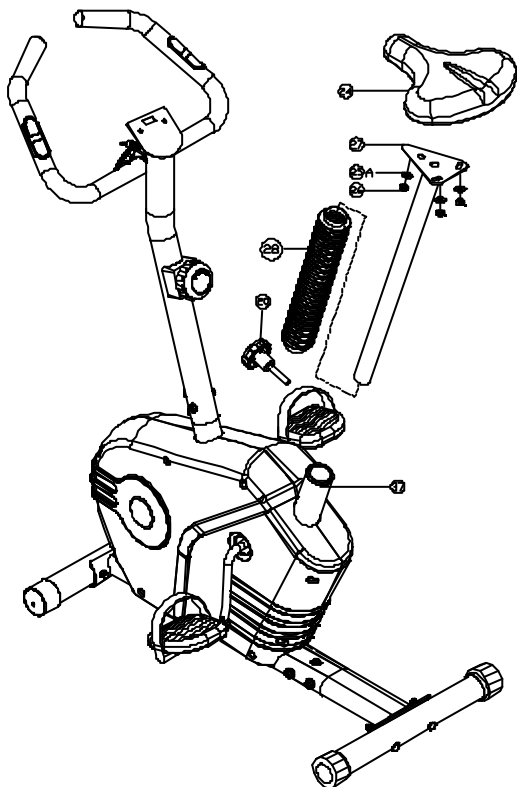

STEP 7

1. Assemble the seat (24) to the seat post (27) with 3 nuts (26) and washers (25).
2. Insert the seat post through the bellow (28) into the base frame through the plastic sleeve(29). Select the ideal height position on the seat post. Insert the knob (29)into the hole. Tighten fully the knob.

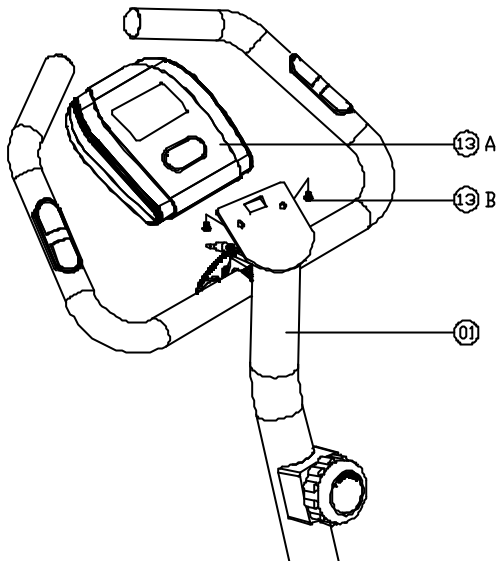

STEP 8

1. Slide the computer (13)A to bracket.
2. Plug in the cable between the computer and the handlebar post.
3. Plug the cable of hand pulse sensor(02) from handlebar into the computer.

7380D Computer Instruction Manual



Buttons:

1. MODE: Press the button to select functions, and hold this button to total reset all function values.

Functions:

1. RPM SPEED: Display exercise speed.
2. TIME: Record exercise time.
3. DISTANCE: Record exercise distance.
4. CALORIES: Record calories consumption during exercise.
5. PULSE: Display heart rate value. High limit could be set as a warning.

Operation:

1. Insert battery, full display with beeper 2 seconds.
2. Display wheel size for 1 second.
3. Press MODE function to see all function values..
4. Start exercise, and all function activated.

Note:

1. Display shut off if no any signal coming in for 4 minutes, press any button or pedaling to turn on the display.
2. In case of improper display, please replace the battery.

*** IMPORTANT SAFETY INFORMATIONS ***

PLEASE FOLLOW THE SAFETY RULES BELOW TO AVOID INJURY AND/OR ACCIDENTS.

1. KEEP THE BIKE AWAY FROM THE ACCESS OF CHILDREN, DO NOT ALLOW THE CHILDREN TO BE AROUND WHEN USING THE MACHINE.
2. DO NOT RIDE THE BIKE STANDING UP.
3. DO NOT RIDE WHILE WEARING LOSSE ROBES, LOOSE PANTS OR SKIRTS.
4. ALWAYS WEAR A BUBBER SLOE SHOES OR TENNIS SHOES WHEN RIDING.
5. PLACE THE BIKE ON A SMOOTH HARD SURFACE.
6. THE USER'S MAX WEIGHT IS 100KGS.
7. THE BRAKING SYSTEM OF THE BIKE IS SPEED DEPENDMENT.
8. THE FIELD OF APPLICATION IS FOR HOME USE.
9. BEFORE EACH USE, MAKE SURE THAT ALL OF THE FASTENERS ON THE UNIT ARE TIGHTENED SECURELY. IF HAVE DEFECTIVE, KEEP THE EQUIPMENT OUT OF UNTIL REPAIR.
10. THE BRAKE PAD IS MOST SUSCEPTIBLE TO WEAR. BEFORE USE, MAKE SURE IT HAVE FUNCTION.
11. THE SAFETY LEVEL OF THE EQUIPMENT CAN BE MAINTAINED ONLY IF IT IS EXAMINED REQLARLY FOR DAMAGE AND WEAR.
12. THIS BIKE NOT SUITS FOR THERAPEUTIC USE.

WARM-UP EXERCISE



15 seconds for each



20 seconds

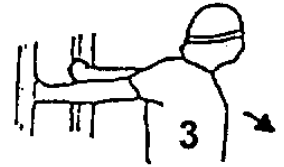

20 seconds

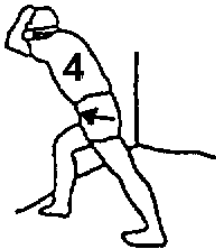

25 seconds

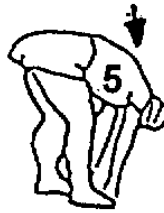

20 seconds



20 seconds



30 seconds

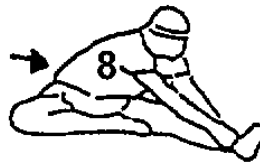

25 seconds for each leg



30 seconds

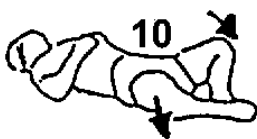

20 seconds



5 seconds x 3 times



20 seconds



20 seconds for each leg



5 times

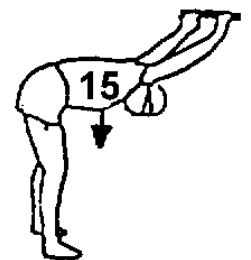

15 seconds